



## Technical Bulletin

Bulletin Number: DF 030110

# **DIRECT FIRED VAPORIZER THERMOSTAT OPERATING PROCEDURE**

*Applicable vaporizer models: 40/40H, 80/40H, 120/60H and 160H-800H*

The purpose of this bulletin is to familiarize the end user with new Algas-SDI thermostatic gas control valve operation.

### **VAPORIZER START UP PROCEDURE**

1. Before starting the vaporizer, close the outlet valve in vapor service line.
2. Fill the vaporizer with LP gas liquid by slowly opening the liquid supply line valve between the storage tank and the vaporizer. If this valve is opened too quickly the excess flow valve in the tank may close. If this occurs, close the liquid supply line valve and allow the excess flow valve to equalize and re-open.
3. If the vaporizer is installed with a separate burner supply line not connected to the vaporizer open the valve supplying gas to the thermostat supply regulator.

- Turn the temperature control dial on the thermostatic gas control valve counter-clockwise to the "RUN" position ("PILOT" on first version). "RUN" position ("PILOT" on first version) indicates that the pilot and main burner can start operating.

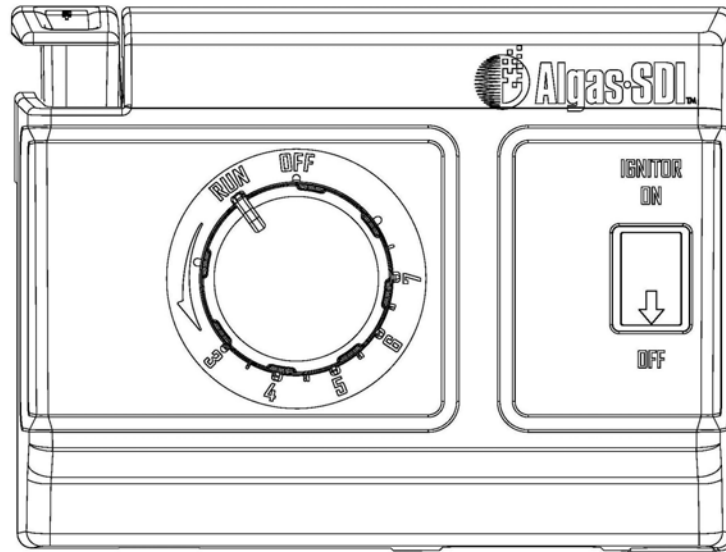

**Figure 1** – Thermostatic gas control valve dial in "RUN" position

- Turn the ignitor switch to "ON". Press the pilot button. Continue to hold the pilot button for 30 to 60 seconds and release. Pilot should remain lit.

**Note:** If the ambient temperature is below 10°F (-12°C) when the pilot button is released it is likely that the main burner will immediately cycle on. As soon as the LP gas inside the heat exchanger heats up above this temperature the main burner will cycle off. This is normal operation for new Algas-SDI thermostatic gas valves and is different than previous gas valves used.

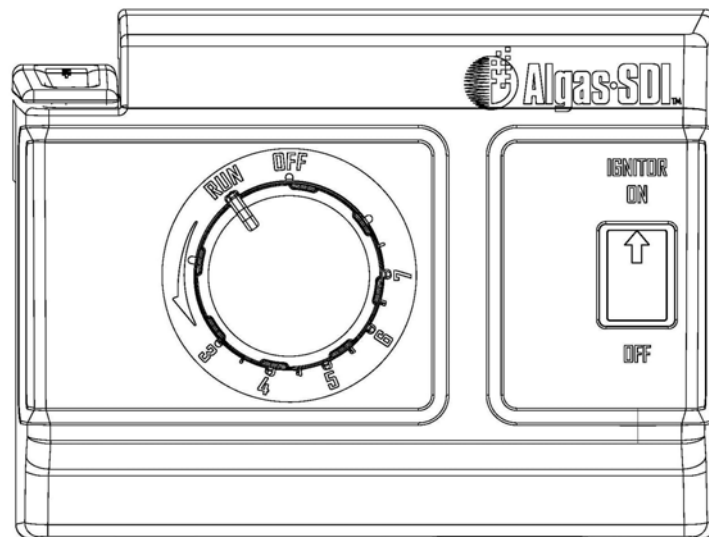
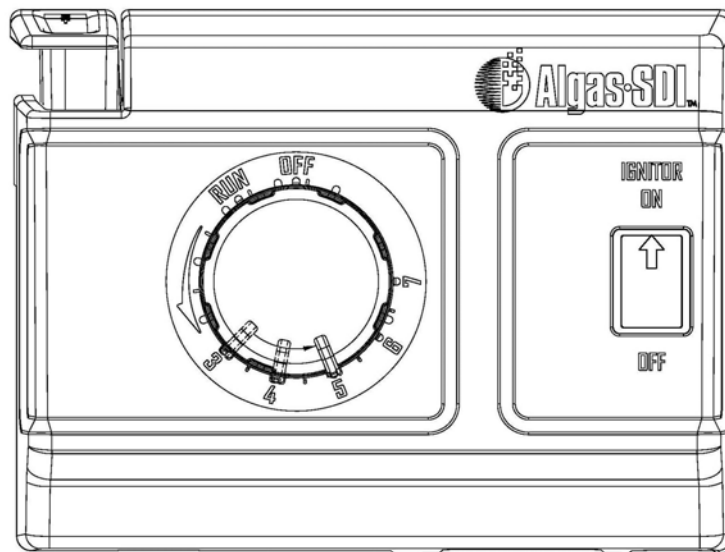

**Figure 2** – Pilot button pressed down and ignitor switch "ON"

6. If pilot light goes off after releasing the dial, turn temperature control dial to “OFF”, wait 5 minutes and repeat step 4.
7. Allow burner(s) to heat the vaporizer until they cycle off.
8. Make sure all the valves on consuming equipment are closed and slowly open the valve in the vapor distribution line. Open all consuming equipment valves.

## **SETPOINT ADJUSTMENT**

Set the temperature control dial so that the outlet temperature is 15°F over the highest ambient temperature during full capacity operation. If a pump is used, set the temperature control dial so that the outlet temperature is 15 °F over the saturation temperature of the LPG during full capacity operation.



*Figure 3 – Rotating temperature control dial counter-clockwise to the desired setpoint*

## **VAPORIZER SHUT DOWN PROCEDURE**

1. Turn temperature control dial to “OFF” position. Pilot flame will immediately extinguish.
2. Once the pilot flame has extinguished turn the ignitor switch to “OFF”.
3. If the vaporizer is below -10°F (-12°C) the main burner may continue to operate for an additional 30-40 seconds until thermocouple cools down.
4. Close the isolation valve ahead of the burner regulator on the side of the vaporizer. This will prevent any fuel from going downstream to the thermostat, pilot and the main burner.
5. If required, it is now safe to disconnect the vaporizer or service the thermostat and the burner.

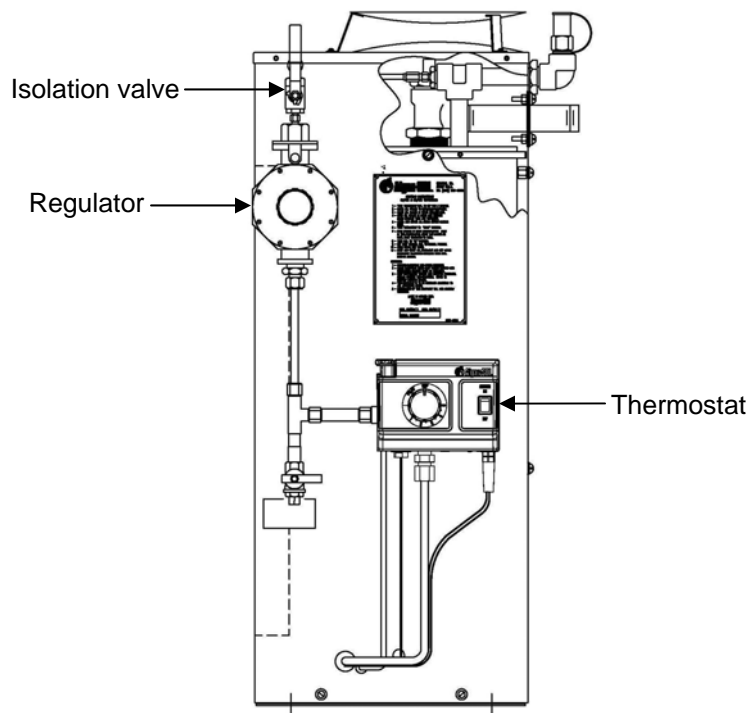

*Figure 4 – Vaporizer shut down procedure*

## **VAPORIZER PURGE PROCEDURE**

1. Close outlet valve at the exit of the vaporizer.
2. Ensure all storage tank valves are open with no restrictions of flow back to the storage tank. A check valve restricting flow back to the storage tank must never be used in a vaporizer installation.
3. If vaporizer is not operating, start the vaporizer per “VAPORIZER START UP PROCEDURE”.
4. After the burner cycles off, shut down the vaporizer per “VAPORIZER SHUT DOWN PROCEDURE”.
5. Before proceeding validate that the burner flame, pilot flame, ignitor spark and any other sources of ignition are completely extinguished.
6. Close tank liquid outlet valve.
7. Open vaporizer outlet valve and flare or allow attached equipment to consume remaining gas in the line.
8. After verifying the pressure in the lines is zero and no sources of ignition are present in the area, vaporizer can now be disconnected.

At Algas-SDI we are committed to continuous improvement and customer satisfaction. If you have any questions regarding this bulletin or have an improvement suggestion you would like to make, please write or phone Customer Service.

151 South Michigan Street, Seattle, Washington, USA 98108  
 Tel: 206-789-5410 Fax: 206-789-5414 Web: [www.algas-sdi.com](http://www.algas-sdi.com)